

USER MANUAL

MONACO



URBAN MOBILITY. ENJOY FREELY.



IT IS IMPORTANT TO READ THE WARNINGS AND INSTRUCTIONS IN THIS MANUAL BEFORE RIDING YOUR NEW BICYCLE



Table of Contents

Welcome	3
Description of symbols	3
Basic information	4
Parts description	5
Intended use	7
Unpacking and assembly	8
Brake System	12
Transmission system	13
Information on the LED Display	19
Error code definition	22
Battery	23
Before the ride	28
Service and maintenance intervals	29
Tyre width and pressure	29
Tightening torques	30
Care instructions	30
List of wear parts	31
Warranty notes	32

Congratulations on the purchase of your BZEN bike

We hope that this is the beginning of a new, exciting adventure for you.

Here is some important information about your new bike, along with step-by-step instructions to complete the assembly of it, and get you out safely on the road.

Some components were removed or adjusted for shipping. However, they can be easily re-assembled or adjusted in just a few simple steps.

If you need any guidance for the maintenance of your bike, please ask your trusted dealer or one of our official Service Partners.

A list with all our official Service Partners can be found here:
<https://support.bzenbikes.com/find-a-service-center/>

Please take the time to read this manual carefully.

The sections marked with the following symbols require your special attention:



"Danger" This symbol indicates possible danger to your life and your health, if the given guidance is not properly followed.



"Warning" This symbol is a warning against incorrect actions that may cause environmental or property damage.



"Info" This symbol indicates additional information about the product or directs you to sites where extra information can be obtained.

Basic information



- EPAC (Electrically power-assisted Cycles) is treated as normal bikes.
- All our bikes comply with the norm 'EN 15194:2017: Cycles - Electrically powered assisted cycles - EPAC Bicycles'.
- The assistance runs by pressure on the pedals and stops when a cyclist reaches the velocity 25km/h or stops pedaling.
- Rated continuous motor power does not exceed 250W and supply voltage does not exceed 48V.



- Use your bike in road traffic only if the equipment corresponds to the country specific road traffic regulations.
- Take note of and follow the country-specific and regional road traffic regulations.
- When riding, wear a bike helmet that corresponds to the country-specific regulations and which has been inspected according to the DIN EN 1078 standard, and bears the CE test mark.
- Attaching child seat to the handlebar or to the handlebar extension is NOT ADVISED
- Mounting child seat directly on the rear carrier is also NOT ADVISED
- Attaching child seat to seat tubes is ADVISED.



Parts description Monaco

- 1 Saddle
- 2 Seat post
- 3 Seat post binder
- 4 Stem
- 5 Handlebar
- 6 Fork
- 7 Frame
- 8 Battery (removable)
- 9 Pedal
- 10 Belt
- 11 Motor
- 12 Front disc brake
- 13 Rear disc brake
- 14 Front belt sprocket
- 15 Front light
- 16 Rear light

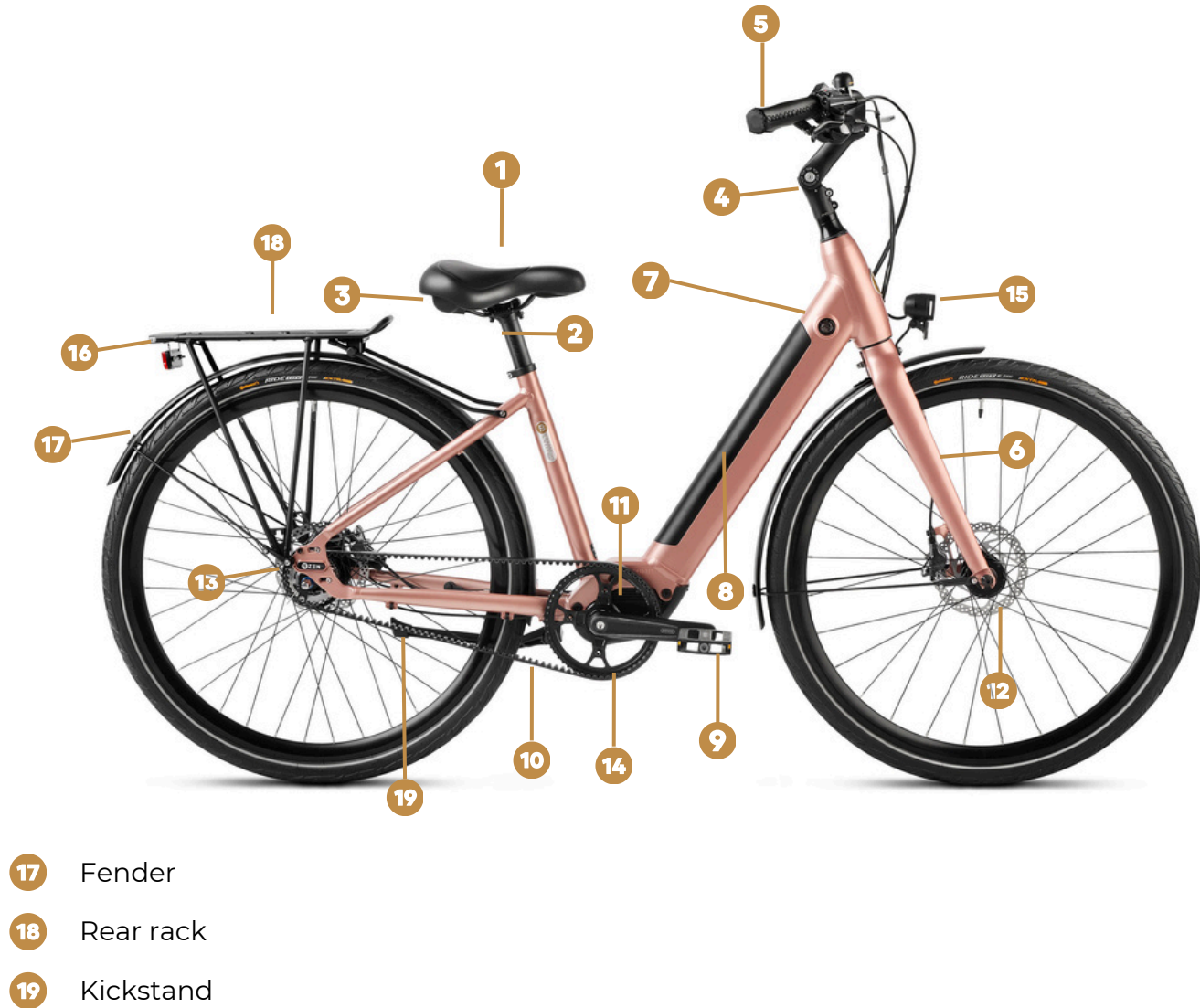

Parts description Monaco

- 1 Front disc brake lever
- 2 Rear disc brake lever
- 3 Gear lever
- 4 Display
- 5 Bell



Intended use

EPAC (Electrically Power Assisted Cycles) are bicycles equipped with an electrical pedal assist drive system.

An EPAC is NOT a moped or motorcycle.

The drive-assist system consists of a drive unit, a battery, a computer control and various electronic components (wires, sensors and control units).

This type of bike has components common with pedal-only bikes. The bike should only be operated on plain or lightly unpaved surfaces (e.g. forest tracks) and only with the required tyre pressure.

The manufacturer and the dealer may not be held responsible for any injuries, claims or damage that arose due to failing to meet the limitations or violations of any safety suggestions stated within this manual.

The manufacturer and the dealer may also not be held responsible for damage or injury caused during races or any other competitive use.

Also the manufacturer and dealer are not liable for any damage or injury caused by poor maintenance and care.



Intended

For paved roads, gravel or dirt roads that are in good conditions, and bike paths

Not intended

For off-road or mountain bike use, or for any kind of jumping

Weight limit

BZEN bikes are designed for a maximum weight of 140kg. The maximum weight is derived from the weight of rider, bicycle, gear (helmet, pannier, shoes, clothes) and luggage.



Child seat (seat tube mounted)

The basic seats generally have a weight limit of 15kg. In real terms this is the equivalent of an average 3 to 3 1/2 years old. Some seats do offer an increased weight carrying capacity of 18kg. Do not exceed the weight limit specified by seat manufacturer.



If there are coil springs underneath your saddle, cover them up. A child sitting in a child seat can get their fingers caught between them.

Unpacking and assembly



The following points must be carried out with the utmost care and all screws have to be fastened with the necessary torque (see also page 30)
risk of accident

- 1 Unpack the bike box and carefully set aside any extra accessories (note: Keep the box! You might need it to return the bike for servicing or repair.)



Please also check out our online video on how to unpack and assemble your BZEN by scanning the QR code or visit www.bzenbikes.com



- 2 Remove the e-bike from the box, clipping the ties from the front wheel and handlebar. Next, remove the foam padding attached to the frame.



If you use a knife to cut the tape, be careful not to damage the frame or other components and cables.

Unpacking and assembly

3 Prepare tools. You will find them inside the box with charger.

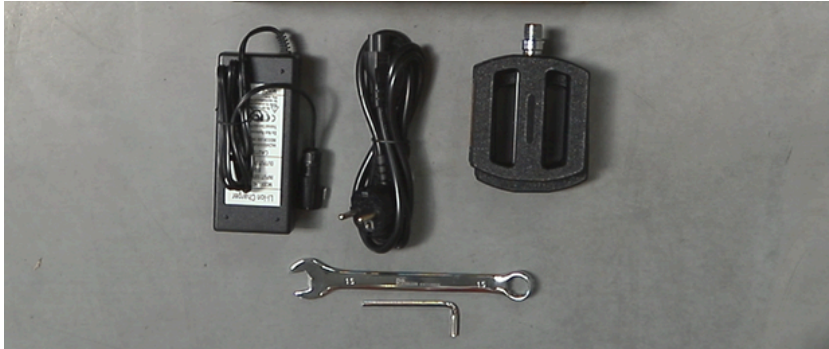

4 Loosen the two side screws of the stem and turn the handlebar. After aligning the handlebar, tighten securely the two side bolts of the stem using 5mm Allen key.

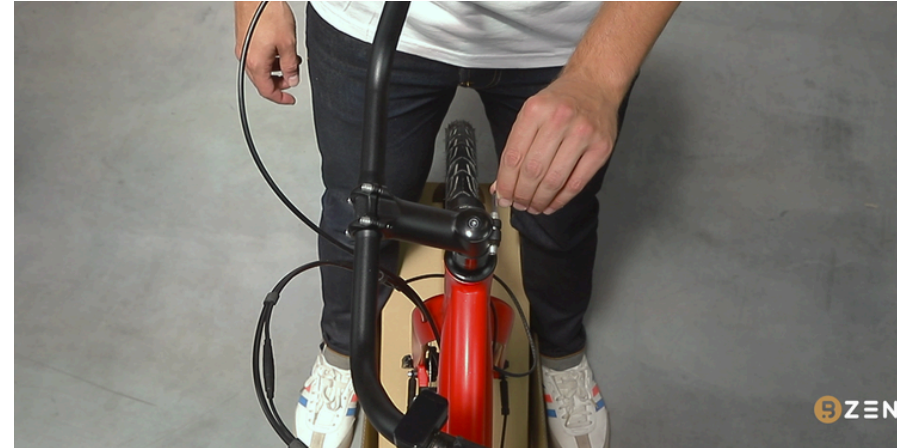

Unpacking and assembly



The pedals and the crank arms are marked with an 'L' (Red) and 'R' (Green) accordingly. The left pedal tightens anti-clockwise, and the right pedal tightens clockwise.

Insert pedals into the crank arms. Ensure that you have the correct left pedal going into the left crank and vice versa. Turn the pedal first with your fingers a few turns. This will ensure that the crank is not damaged or twisted. Then use the wrench at the end to ensure that the pedal is on tightly. A tight pedal-crank is very important for your safety.

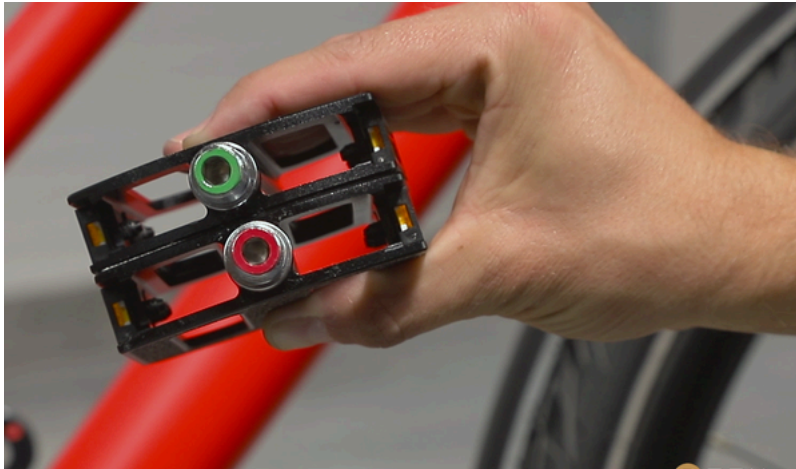

Unpacking and assembly

- 6 Set the saddle height for your needs



The seat post must be placed into the frame deeper than the MINIMUM INSERT safety line which is indicated on the post.

- 7 How to adjust angle of the adjustable stem

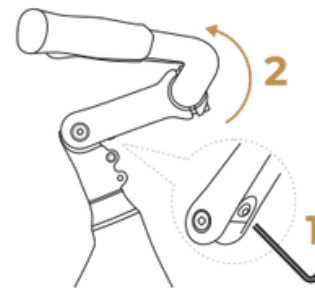

A lock / unlock

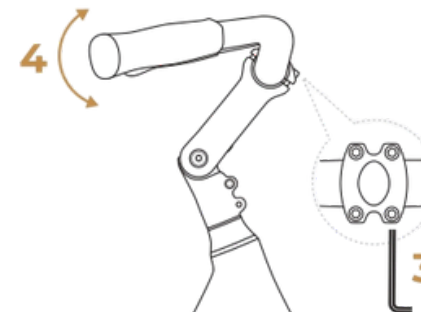

B adjust handlebar



Please use the 5mm Allen key provided with the accessories box. Don't forget to set the handlebar to the desired angle after the angle of the stem has been changed. For this, you can unscrew the four bolts of the stem face plate and turn the handlebar (see B)

Brake System



The rear brake is located on the right-hand side of the handlebar, and the front brake is on the left hand side. If the positioning of the brake levers on your bike is new and unfamiliar, you will have to be careful on your first rides. Make yourself familiar with the functioning and power of the brakes while riding at reduced speed



Risk of accident due to reduced braking performance caused by brake pads that are not broken in! Disc brakes can only achieve full braking power when the brake pads are broken in. Choose a place off public roads to break in the pads:

- Brake 20 to 30 times with the front or rear brake from a speed of 25km/h down to 5 km/h and repeat the process for the second brake. You should brake as hard as possible without locking one of the wheels.
 - Please also note the instructions of the brake manufacturer (see enclosed manual). In case of any deviations, the component manufacturer's instructions apply.
-

Transmission System



The BZEN Monaco is equipped with a modern Gates Carbon Drive™ belt drive system combined with a Shimano Nexus 8-speed internal gear hub.



Do not modify this bicycle drive system in any way or for any reason. Doing so may result in serious damage, incorrect or dangerous conditions of use, or violations of local laws.

Gates belt drive

Gates carbon Drive™ belts are extremely durable and offer long life when properly handled. However caution must be used before and during installation to avoid damaging carbon tensile cords that make up the backbone of the belts's strength. Excessive bending and twisting creates rimps which can lead to belt breakage under high load



Drive belt and sprockets do not need lubrication of any sort. For cleaning use only water and a soft brush. Please do not use any type of detergent



Do not crimp, twist, back bend, invert, bundle or zip tie the belt. Do not use the belt as a strap wrench or chain whip. Do not roll on or pry up on the belt.



Lack of belt tension can lead to tooth jump or skipping, when the teeth of the belt slide over the teeth of the rear sprocket. Too much tension can damage bearings, cause system drag or increase wear on the drive train. The method for checking the adjustment of the belt can be found on manufacturer's website. We strongly recommend to contact your nearest Service Partner in case the adjustment is needed.

Internal gear hub

Adjusting the cassette joint

First move the shifting lever from 1 to 4. Check to be sure that the yellow setting lines on the cassette joint bracket and pulley are aligned at this time.

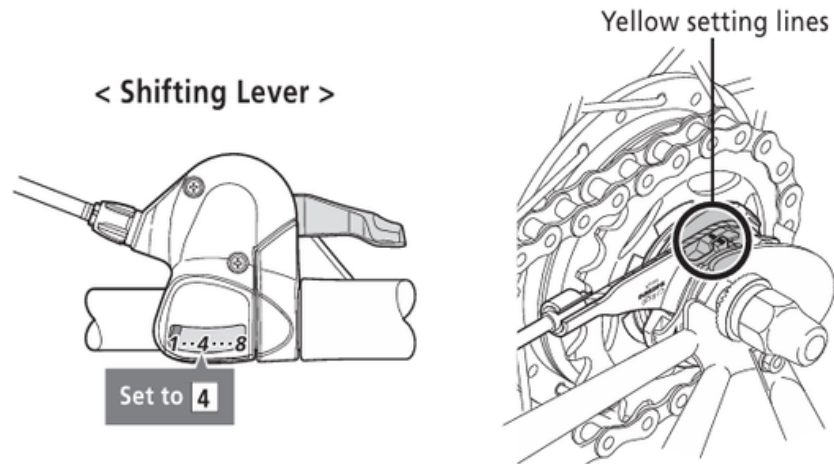

The yellow setting lines on the cassette joint are located in two places. Use the one that is easiest to see.

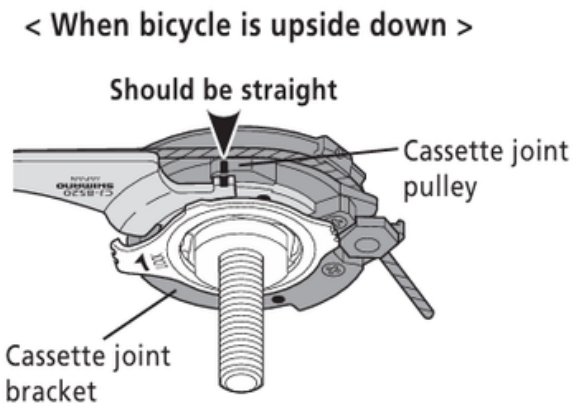
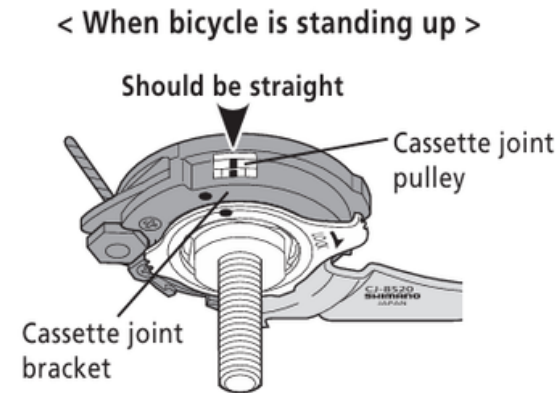

i

The internal gear hub is the SG-C6001-8D combined with the SL-S503 Rapidfire Plus shifter. For the complete operating instructions, scan the QR code or use the following link: <https://si.shimano.com>



Internal gear hub

Adjusting the cassette joint

If the yellow setting lines are not aligned, turn the cable adjustment bolt of the shifting lever to align the setting lines. After this, move the shifting lever once more from 4 to 1 and then back to 4, and then re-check to be sure that the yellow setting lines are aligned.

< Shifting Lever >

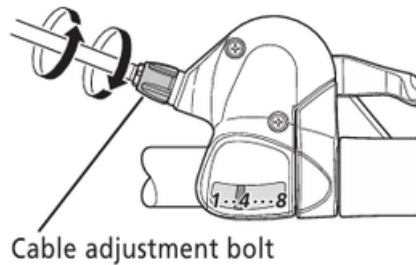

After adjusting the cassette joint, cut off the excess length of inner cable and then install the inner end cap

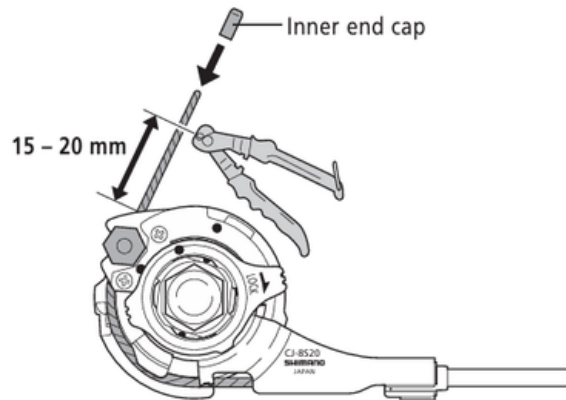

In order to remove the rear wheel, the cable from the cassette joint has to be disconnected

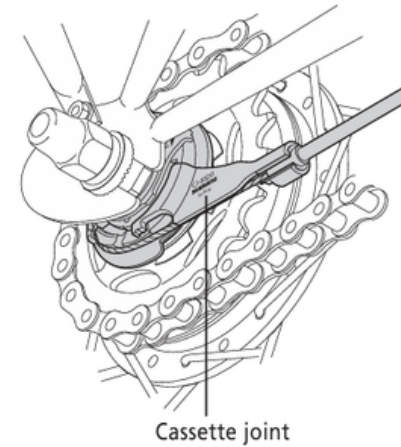

In order to correctly disconnect the cassette joint, the first step is to set the shifting lever to 1.

< Shifting Lever >

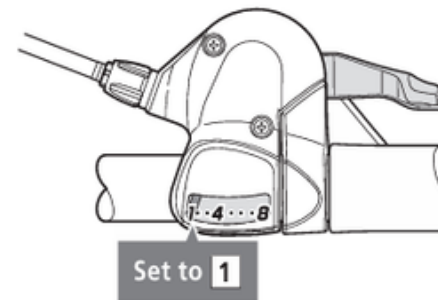

Internal gear hub

Disconnecting the shifting cable to remove the rear wheel

The second step is to pull the outer casing out from the outer casing holder of the cassette joint, and then remove the inner cable from the slit in the cassette joint bracket.

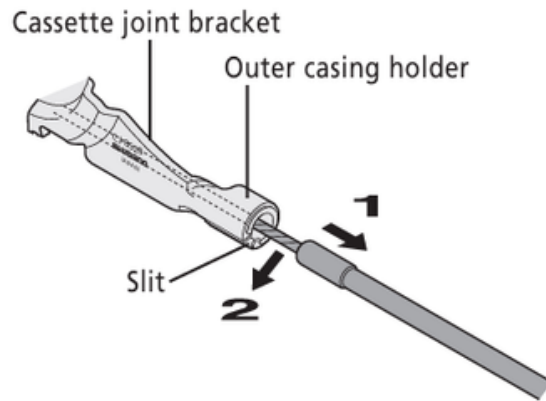

Next, remove the inner cable fixing bolt unit from the cassette joint pulley.

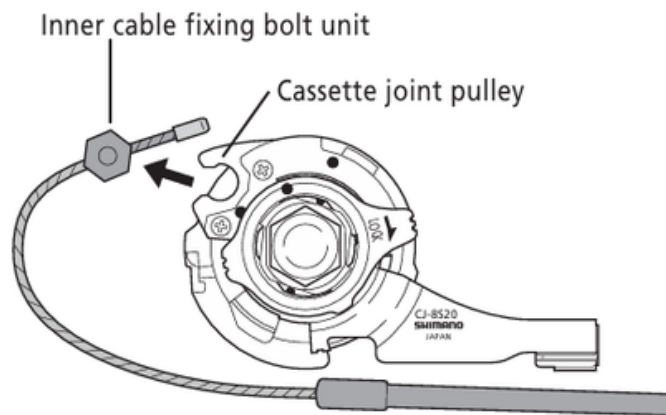

If it is difficult to pull the outer casing out from the outer casing holder of the cassette joint, insert a 2 mm Allen key or a #14 spoke into the hole in the cassette joint pulley, and then turn the pulley to loosen the inner cable. Then remove the inner cable fixing bolt unit from the pulley first, and after this remove the outer casing from the outer casing holder.

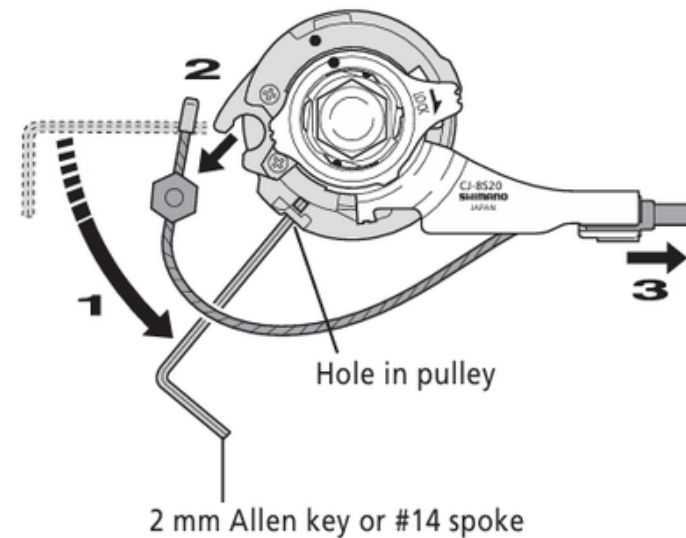

Internal gear hub

Reconnecting the shifting cable

If reusing the shifting cable, follow the next steps to reconnect the cassette joint.

First, bring the cable around to the cassette joint pulley, hold so that the inner cable fixing nut is facing to the outside (toward the fork end), and then slide the flats part of the inner cable fixing washer into the gap in the pulley.

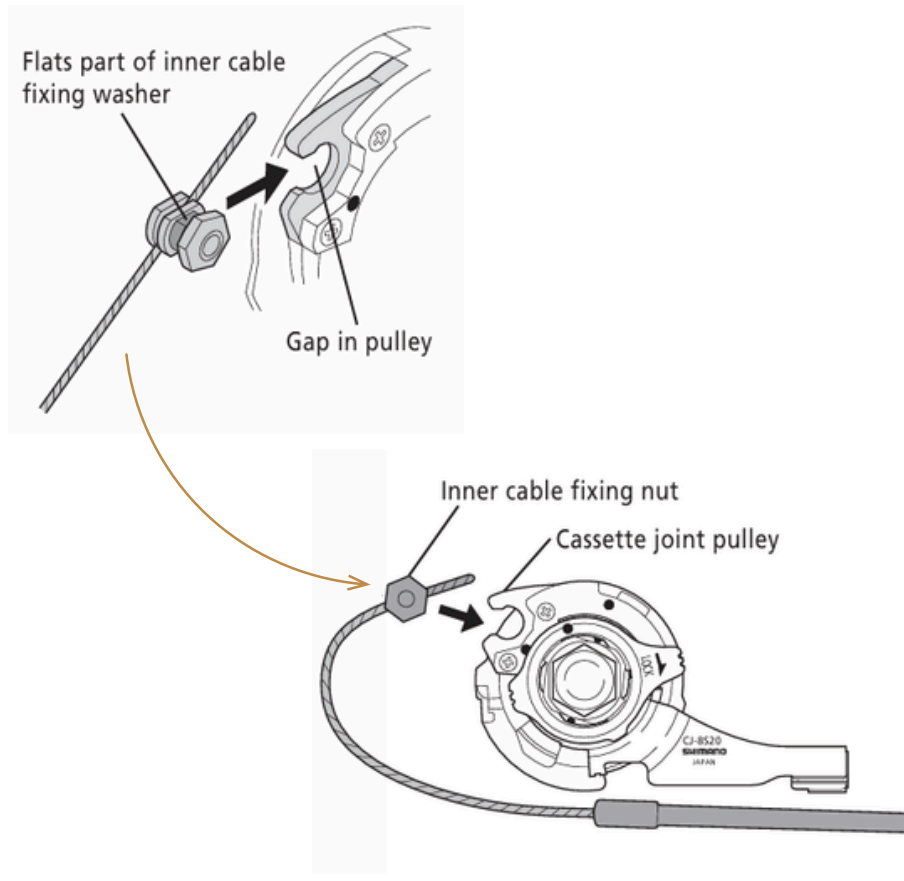

Second, turn the cable 60° counterclockwise and attach it to the hook.

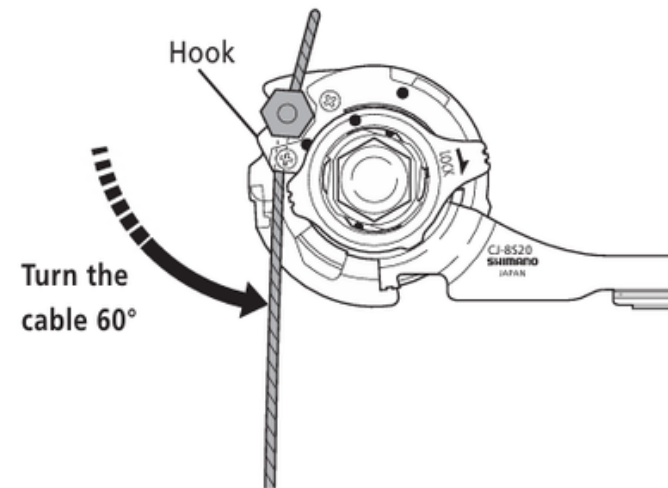

Internal gear hub

Reconnecting the shifting cable

Attach the inner cable to the pulley as shown in the illustration, pass the inner cable through the slit in the cassette joint bracket, and then insert the end of the outer casing securely into the outer casing holder.

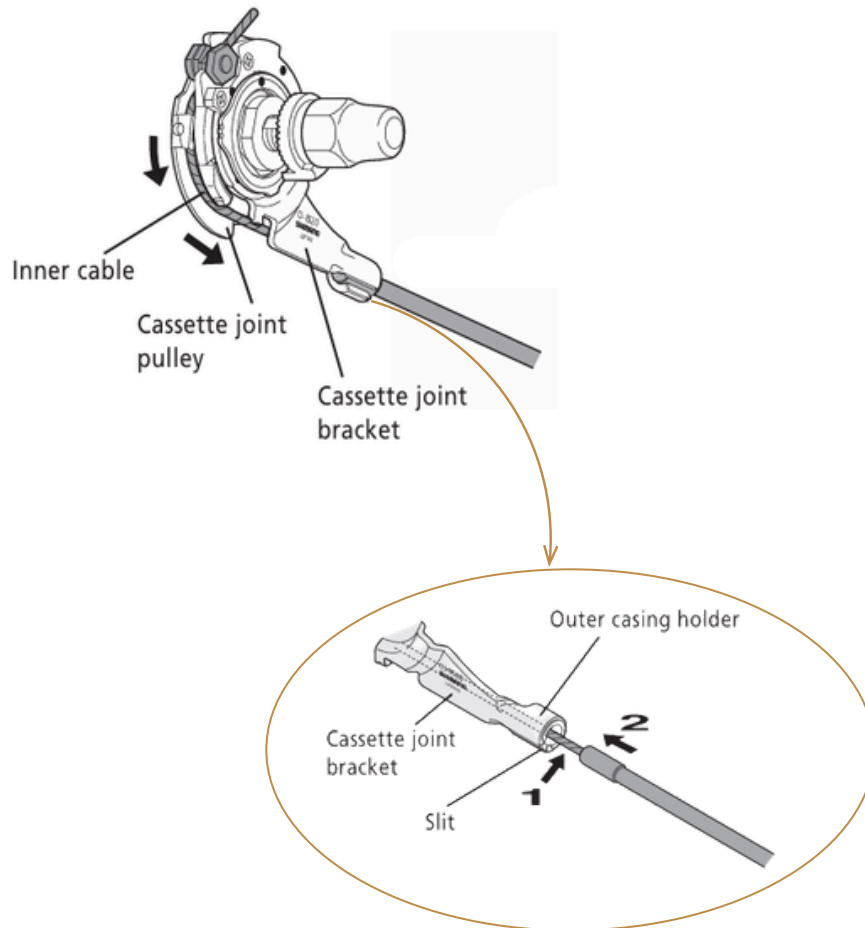

If first inserting the outer casing into the outer casing holder is easier, then first insert the outer casing into the outer casing holder, and then insert a 2 mm Allen key or a #14 spoke into the hole in the cassette joint pulley, and then turn the pulley so that the inner cable fixing bolt unit fits into the gap in the pulley.

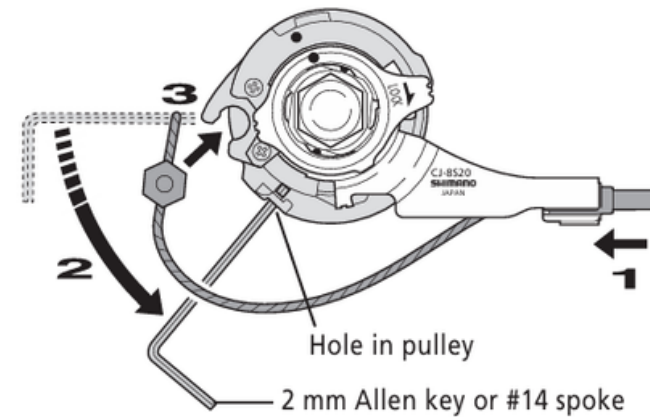

Information on the LED Display

Display

BZEN Bikes are equipped with an electric support system. On the handlebar you can find the E160 Bafang display with:

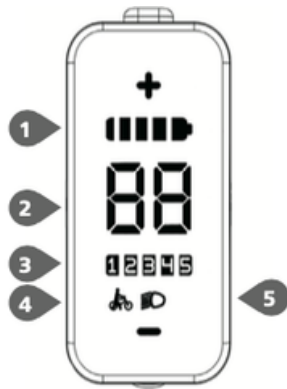

- 1 Battery capacity indicator
- 2 Speed indicator
- 3 Support level indicator
- 4 Walk assistance
- 5 Indicator for lighting system



For the complete operating instructions, scan the QR code or use the following link:
<https://www.bafang-e.com/en/oem-area/service/UserManual>.



Key Definition Display

The E160 Bafang display has three buttons: System On/Off, Up, and Down

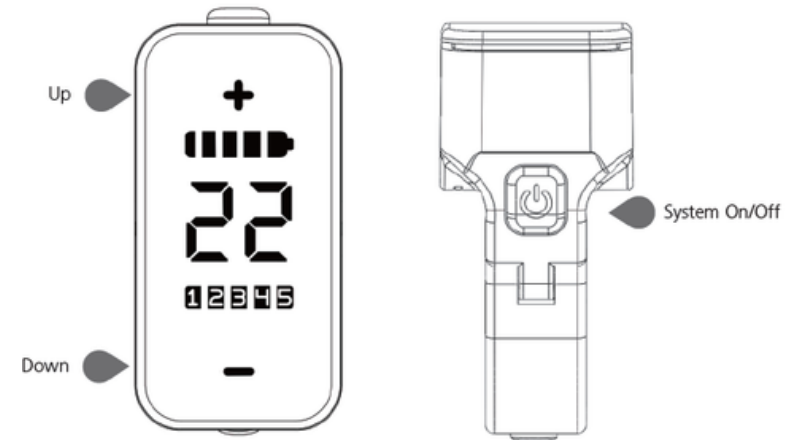

Switching the system ON/OFF

Press and hold the On/Off button (>2S) until the display turns on the system.

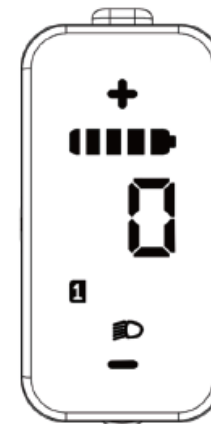

Information on the LED Display

Selection of Support Levels

When the display is turned on, press the UP button or DOWN button to switch to the desired support level. The lowest support level is 1, the highest support level is 5. When the system is switched on, the support level starts automatically at level 1. You can choose to have no support by going down to level 0 (no support bar is displayed).

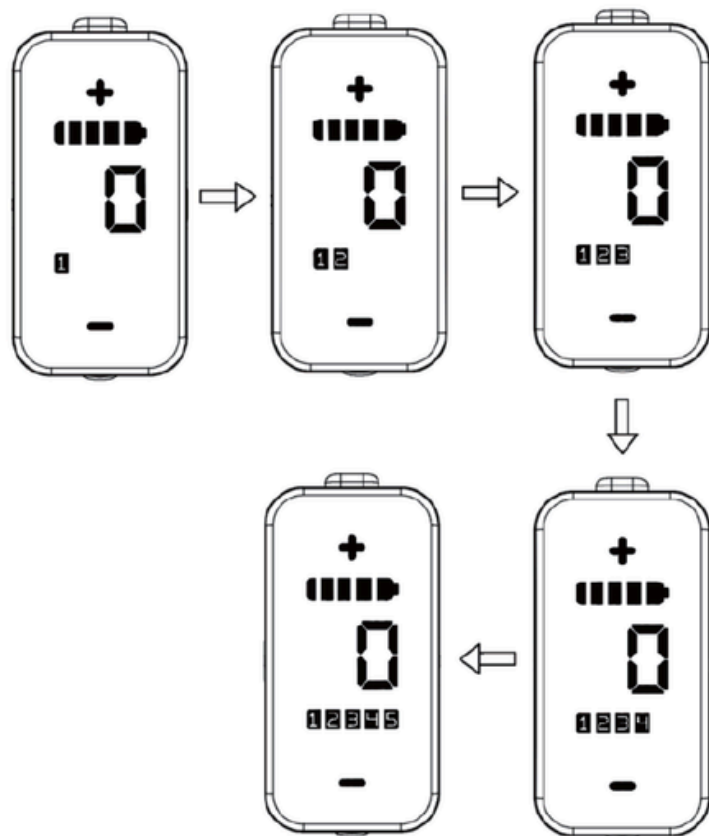

Front light/ Rear light

Keep the UP button pressed (>2S) until the front light and rear light are activated.

Hold the UP button again pressed (>2S) to turn off the front light and rear light.

If the display is turned on in a dark environment, the display front/rear light will be turned on automatically. If the display front/rear light are turned off (or on) manually, they also need to be turned on (off) manually afterwards.

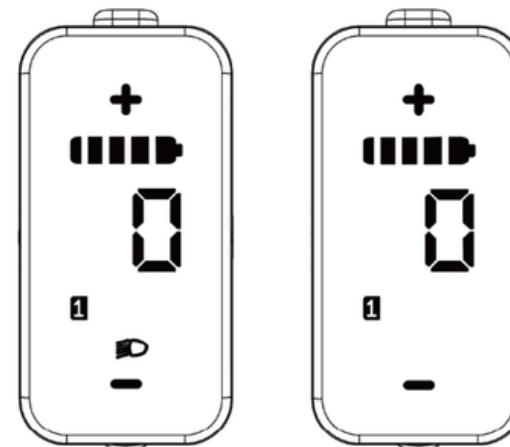

Information on the LED Display

Walk assistance

When your e-bike is standing still, briefly press the DOWN button until the walk assistance indicator is displayed (see picture below). At this point, keep the DOWN button pressed, and the e-bike enters the walk assistance mode, the indicator will flash. If you release the DOWN button, the walk assist will stop. If no operation is happening within 5 seconds, the system will automatically return to support level 0.



Walk assist indicator

Battery capacity indication

The battery capacity is indicated with 5 levels. When the lowest level indicator flashes, it means that the battery needs to be charged. The battery capacity is shown as follows:

Indication definition	SOC	Example
5 bars	80%-100%	■■■■■
4 bars	60%-80%	■■■■□
3 bars	40%-60%	■■■□□
2 bars	20%-40%	■■□□□
1 bar	5%-20%	■□□□□
1 flashing	<5%	■□□□□



From approx. 20% remaining battery capacity, the system automatically switches to power-saving mode. In this case, the maximum motor support is reduced to extend the riding range.

Error code definition

The display can provide warnings for failures. by means of error codes. The error code flickers on the display, when an error is detected.

Please read carefully the description of the error codes. When the error code appears, please first restart the system. If the problem is not eliminated, please contact one of our official Service Partners or contact us via support@bzenbikes.com.

The table below shows a non-exhaustive list of potential error codes:

error code	error definition	solution
07	Over voltage protection	Update controller or change battery
08	Error with hall sensor inside motor	Let your nearest Service Partner check the motor
10	The motor temperature reaches the max protection value	Let your motor cool down
12	Error with current sensor inside controller	Have your nearest Service Partner check the controller
13	Error with temperature sensor inside battery	Have your nearest Service Partner check the battery

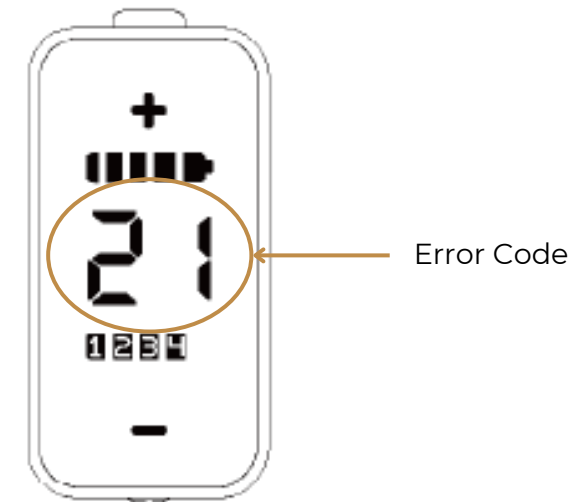

Battery

Removing and reinserting the battery



The battery is the Bafang BT F020.B504.C. For the complete operating instructions, scan the QR code or use the following link: <https://www.bafang-e.com/en/oem-area/service/UserManual>



- 1 Turn the key in the lock to the right to open the locking mechanism of the battery. You will notice the top parts of the battery will come a few centimeters away from the frame.



Battery

Removing and reinserting the battery

- 2 Then hold the two sides of the battery to pull the battery out of the frame.



- 3 To reinsert the battery, start with the downside of the battery first and then insert the topside into the frame. You will notice a clicking noise, when the battery is correctly inserted. The lock will be automatically closed. Remove the key.



Do not leave the key in the lock while riding, as it may fall out and get lost.

Battery

Checking the charging status of the battery

Press the black button for 1 second to indicate the state of charge from the LED on the battery.

- blue is full,
- green is medium,
- red is low,
- flashing red is critical

Check your LED display on the handlebar to get more detailed information on the charging status of your e-bike (see page 21).



Button for battery charge indication

Battery

Battery charging instructions



- To prevent the risk of electric shock, you should never open the charger. Maintenance work may only be carried out by qualified service personnel.
- Be sure to read the information about your charger before use!
- Unplug the power plug before connecting the battery to the charger or removing it from the charger.
- Keep the charger away from children and animals. In the event of malfunction or damage, it may result in a fire or electric shock.
- The charger must not be operated by children or people with limited sensory or mental disabilities.
- Do not use your charger if it is moist or dusty.
- Avoid direct sunlight.
- Disconnect the charger from the power supply when not in use.
- Use only the original Bafang charger that came with your pedelec as there is a risk of fire or explosion if the incorrect charger is used.
- Do not cover the charger while in use. There is the possibility of short circuits or fires.
- When cleaning the charger, unplug it from the power outlet first.
- Stop the charge process if the charging cycle lasts longer than the length listed in the Specifications table.
- Before using, check that the charger, cable and plug are not damaged. Do not use the charger, if you notice any damage. There is a risk of electric shock.
- Charge the battery only in a well-ventilated room.
- Charge the battery in a dry place, and on a non-flammable surface.
- Note: A sudden rise in temperature can cause condensation in the battery. To avoid condensation, charge the battery at the same place where it is stored.

Battery

Battery charging instructions

- i** Lithium-ion batteries are not subject to any memory effect. You can recharge your battery at any time, even after short journeys.
- i** You can charge your battery when mounted on the bike (1) or when it is removed (2)



Battery

Battery charging instructions

- i** The charger is specially designed for charging lithium-ion batteries. It is equipped with an integrated fuse and overcharging protection.
- i** Before charging, please read also the instructions on the charger. Always closely monitor the battery during charging.

- 1** First plug the connector of the charging cable into the charging socket in the battery, then connect the charger into a wall socket.
- 2** As soon as the charger is connected to the power supply, a red LED will light up.



- 3** When charging is complete, the LED changes from red to green



Battery

Battery charging time



The charging time depends on several factors. It can vary greatly depending on the temperature, age, use and capacity of the battery.

When the battery is empty, a full charge takes 6-8 hours with a 2A charger. When the battery is fully charged, the charging process stops automatically. Unplug the connector from the battery and then removed from the mains.

Battery care

Battery wear and storage



- The battery can be charged 600 times. The battery capacity decreases during this time, thus reducing the range of the pedelec. If battery's capacity range is not enough, it may need to be replaced.
- It is recommended to charge the battery after use. Deep discharge is harmful to the battery. Never fully discharge the battery.
- It is best to charge the battery at room temperatures and insert the battery just before the start of the journey.
- When not in use, you can optimise battery life span, by charging your bike every 2 months to avoid damage or destruction of the cells. If the battery remains uncharged for an extended period, this will damage the capacity of the battery.
- For storage, the recommended capacity of the battery should be between (60-80%). Store the battery separately in a suitable dry place.
- It is not recommended to have the battery pack permanently connected to the charger.
- Avoid direct sunlight from the sun, as it may cause it to overheat, and cause internal problems in the battery. It can lead to abnormal chemical reactions or malfunctions that lead to overheating, smoke and explosion.
- To prevent a deep discharge, the battery is put into sleep mode after a certain time.
- Do not extend the battery to temperatures below the permissible storage temperature of -10 °C to 35 °C. Note that temperatures of about 45 °C are common near heaters, in direct sunlight or in overheated vehicle interiors.
- Charge the battery at temperatures between 0°C and 45°C (ideally at room temperature approx. 20 °C). Give your battery enough time to reach this temperature before charging.

Battery care

Safety instructions



- Do **not connect the battery to an incompatible system**. It is possible for the battery to cause a fire, explosion or hazard in this case.
- Do **not dismantle the battery pack**; doing so may result in short circuiting the battery system. Dismantling of the battery pack will void all warranties.
- If the **battery falls to the ground**, or exposed to a blow or similar event, **do not continue to use the battery**, take it to your retailer to examine.
- **Use only the original charger** supplied with the battery, otherwise it can lead to an explosion or permanent damage.
- The **disposal of used batteries** must be carried out at a suitable disposal point.
- The battery should **always be kept out of reach of children**.
- The **leaking of battery fluids** may cause burns or irritations to the skin. If the battery fluid leaks due to improper usage, avoid touching the leaked battery fluid, clean with large amounts of water immediately. If the battery fluid comes in contact with your eyes, seek medical attention immediately.
- **A faulty battery can lead to overheating, smoking or burning**. When the battery gets hot keep yourself and others a safe distance away from the battery. In case of damage or heat, you should avoid touching the battery.
- **Do not intentionally short-circuit the battery**. Never allow the plus and minus connectors to come into contact with each other. Do not allow the battery to come into contact with metal objects. It is dangerous if the battery is short-circuited. As it can lead to overheating, smoke, explosion or burning.
- **Do not heat or burn the battery**. An overheated or ignited battery can cause battery cells to explode.
- **Do not use the battery near heat sources**. Do not use the battery near an open flame or at temperatures above 60 °C. High temperatures can cause the battery to burn or explode.
- **Do not charge the battery near open fire or in direct sunlight**. This can cause errors or internal problems inside the battery, also damaging the protective function. It can lead to abnormal chemical reactions or malfunctions that lead to overheating, smoke and explosion.
- **Do not damage the battery**. The battery must not be dropped or damaged. This can lead to overheating, smoke and explosion. Never submerge the battery in water.
- **Do not charge the battery directly from the socket or a cigarette lighter in the car**. High voltage and excessive current will damage the battery and reduce its lifespan. It can lead to overheating, smoke and explosion.
- **Do not continue to use the battery if you notice that it gets hot during operation, charging or storage**, develops a strong smell, changes its appearance, or is otherwise unusual. Do not continue to use the battery and have it checked by a retailer before using it again.

Before the ride

- Check the battery charge status
- Check that the wheels are straight. Lift the wheels one after the other and spin them. The wheels must spin smoothly. The wheels must run evenly, without moving up and down or from side to side. The tyres must not run against the frame
- Check the tyre pressure. The best way to check the pressure of the tyres is to use a floor pump with a pressure gauge.
The tyre pressure must not fall below or exceed the minimum or maximum value (see also page 24)
- Check the tyres for damages and wear. The tyres must not be damaged. The tyres must not be worn so that the puncture protection belt or the carcass threads can be seen through the tread.
- Make sure wheel quick releases are firmly closed.
- Check the bite point of the brakes: Pull one brake lever after the other while standing. The bite point must be felt around half way down the brake level travel.
- Check the braking performance. Pull one brake lever after the other, while standing and push the bike backwards and forwards. Front and rear wheel must lock when the brake lever is pulled
- Check the brakepads for wear. The thickness of each brake pad must be 0,5mm or more
- Check the brake discs for wear. Minimum thickness of Shimano brake rotors: 1,5mm
- Check the frame for damages and deformation. There must be no damages.
- Check that brake fluid is not leaking from the brake lines and connections and that they are not damaged. Brake fluid must not leak from the connections.
- Verify the tight fit of the stem. Stand in front of the bike with the front wheel between your knees. Try to turn handlebar left and right. It should not be possible to turn handlebar with normal force
- Check if the headset has no play. Stand next to your bike with both hands on the handlebar. Pull the front brake and try to push the bike gently backward and forwards. You should not notice any play.
- Verify the tight fit of the seat post. Stand behind your bike, hold the saddle with one hand and try to turn it left and right. It should not be possible to turn the saddle or seat post.
- Make sure that all parts are tight. Loose parts must be tightened to the proper torque (see also page 30).
- Check the belt condition. Make sure it is clean and in good condition. Rotate the crank to inspect the entire length of the belt for cracks, cuts, or frayed edges. Belt wear is greater compared with pedal only bikes. This requires frequent inspection and replacement.
- Check the belt tension (if bike is equipped with belt drive)
- Check the bicycle front and rear lighting to make sure it works properly.
- Inspect condition of electrical cables (i.e. kinks free, no signs of abrasive wear).
- Test the drive-assist system, make sure the drive system functions normally.

Service/maintenance intervals



When neglecting maintenance and service, worn components may cause accidents. The service works and intervals mentioned in this manual must be observed. Service and maintenance works must be carried out by a qualified bicycle mechanic. If any parts must be replaced please use only original parts specified by manufacturer.

Service intervals

- 1 After 500 to 1000km or six months after purchase date at the latest
- 2 After 3000 to 4000km or two years after purchase date
- 3 After 5000 to 7000km or three years after purchase date



MANY BICYCLE SERVICE AND REPAIR TASKS REQUIRE SPECIAL KNOWLEDGE AND TOOLS

Do not begin any adjustments or service on your bicycle until you have learned from your Service Partner how to properly complete them. Improper adjustment or service may result in damage to the bicycle or in an accident which can cause serious injury or death.

Tyre width and pressure



On bicycles with originally fitted tyres the maximum tyre pressure can be determined from the marking on the sidewall of the tyre



The Maximum allowed tyre width for BZEN bikes is 45mm (measured width). The nominal width stated on the sidewall of the tyre and the actual measured width may differ depending on the manufacturer.



Tightening torques



Too much torque can cause damage or the failure of a part. Too little torque can cause the part to come loose or break from fatigue failure. Use a torque wrench to correctly tighten a part, or bring the bicycle to your bike shop for service.

Part	Bolt size	Torque
Hub nut	M5	8Nm
Hub axle	M6	8Nm
Stem fork clamp	M5	7Nm
Stem handlebar	M5	7Nm
Clamp	M5	3Nm
A-Head cap	M5	10Nm
Seat post clamp	15mm	35Nm

Care instructions



Do not immerse the e-bike system or any individual e-bike component in water, and do not wash any e-bike component with high pressure washing equipment. The system is designed to operate in rain and other adverse weather conditions. Damage due to pressure washing or other heavy cleaning may void the system warranty. Keep all components of the e-bike clean, especially the electric contacts on the battery pack and frame. Use a soft, damp cloth to clean them thoroughly.

List of wear parts

Some parts in your bike may require periodical exchange. Several mentioned in this manual have a significant influence on your safety. Please refer to pre-ride checklist for details.



- Brake pads/motor
 - Tyres and tubes
 - Front and rear sprocket
 - Tooth belt
 - Rims
 - Bearings
 - Saddle
-

Warranty notes

Every new BZEN bike has a statutory warranty for 2 years from the date of delivery. The warranty covers our frames and all original components against manufacturing and material defects.

In case of the sale of a second-hand bike (e.g. a demo bike), the statutory warranty is limited to 1 year.

This statutory warranty is limited to the replacement of the defective frame or parts and is the sole remedy of the warranty.

The action shall be time-barred within one year from the day on which the purchaser discovered the lack of conformity, without this period expiring before the end of the two-year period provided for in § 1. However, claims under this warranty must be made within two months of the buyer's discovery of the defect. They must be made directly on our website under support/warranty or by e-mail to support@bzenbikes.com. If you registered on the BZEN website, your name and e-mail address will serve as proof of purchase. If you did not register on our website, please provide a copy of your invoice.

This warranty does not cover normal wear and tear, improper assembly or maintenance of the bicycle, or the installation of parts or accessories. The warranty does not apply to damage or failure due to accident, misuse, abuse or neglect. Modification of the frame or original components will void this warranty. BZEN SRL is not liable for incidental or consequential damages.

Labour costs related to parts changes are only covered by the warranty only where the choice of repairer has been approved by BZEN.

This warranty does not affect the legal rights of the consumer.

In addition to the statutory warranty, we voluntarily grant for 2023 models and onwards an extended guarantee of 5 years in total from the date of invoice for BZEN frames and BZEN forks, excluding bearings and shocks as well as damages to the paintwork/anodisation.

Without any limitation of the statutory warranty rights of the Customer, our voluntary guarantee is subject to the following additional conditions: The guarantee does not cover damages caused by inappropriate or unspecified use according to the fields of use for the particular product as described on our website and our user manual, as for example: Neglect of product; modifications to frame or fork (for example engravings or lacquering); crash; excessive load; jumps; mounting and alteration of additional components that were not expressly approved by us or replacement of our original components by components that do not have a similar quality.

Guarantee rights are limited to the aforementioned and any additional incurred costs (such as assembly, transport, etc.) and additional costs for assembly or material due to a model-change are not covered. Within the framework of our voluntary guarantee, the Customer shall bear these costs.

Our guarantee is valid and only for the original buyer of the product.
